

MONTAGGIO RACCORDO INGRESSO VERSIONE LATERALE

MONTAGGIO RACCORDO INGRESSO VERSIONE POSTERIORE



TABELLA PRESTAZIONI CONSUMI

Apertura fessura doppia = 0.1 mm per lato fessura

Pressione (Bar)	Consumo aria (NL/min)	Consumo aria (m3/h)	Forza di spinta misurata alla distanza di 200 mm (grammi)
1	142	8.5	61
2	250	15	123
3	352	21.1	200
4	442	26.5	280
5	508	30.5	355
6	612	36.5	445

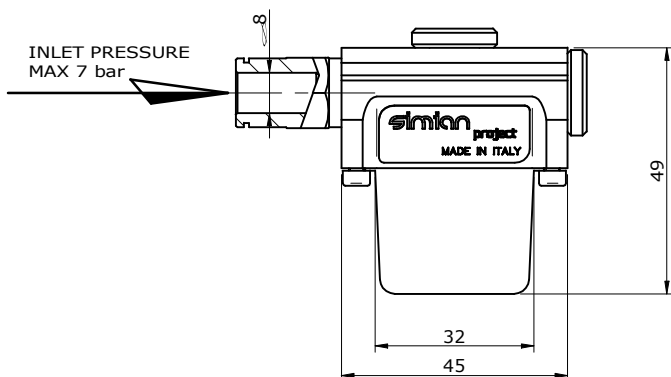
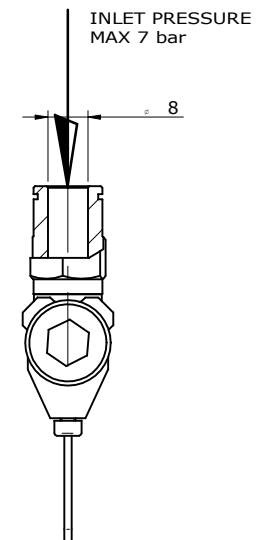
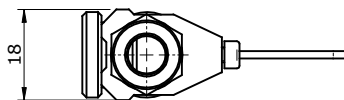
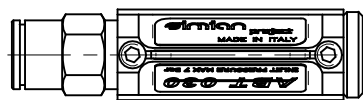
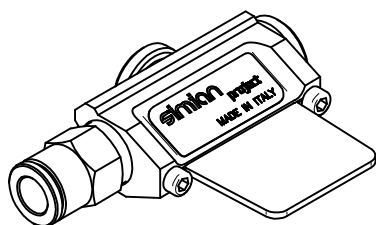

simianproject.com

SCHEDA TECNICA PRODOTTO

LAMA D'ARIA L=30 mm	DATA/DATE 03/01/2017	
	AUTORE/AUTHOR L.Lombardi	
	PESO/WEIGHT 0.000 kg	SCALA/SCALE 1:1
	CODICE/CODE 90ABT030-S	REV. 00

UNIVERSITÀ DI PAVIA - UNIVERSITÀ DI PAVIA

(420x297)